

## ACTIVITY EIGHT: CUBING

Cubing is one way to explore every side of a topic. You hear people say all the time that “There is more than one side to an issue.” Cubing is a way to visually see an issue’s different sides.

### Objectives

1. Students will explore key concepts and strategies of the Movement.
2. Students will take positions on key concepts of the Movement.

### Time & Materials

One class session  
Example for class to see (use the one on “non-violence,” next page)  
*Free at Last* text  
Copies of “Cube” — one for each student (see reproducible pages)

### How to Cube

**Step One:** Introduction of the topic.

**Step Two:** In small groups, students explore the topic from the following six sides of the cube.

Describe it (What color is it? What shape and size?)  
Compare it (What is it similar to or different from?)  
Associate it (What does it make you think of?)  
Analyze it (How is it made? What is it composed of?)  
Apply it (What can you do with it? How is it used?)  
Argue for or against it (Why should I support it? Why should I take a stand?)

**Step Three:** This process can be elaborated through optional writing assignments, including essays, letters to the editor or extended reports.

The following page is an example of cubing explaining the concept of non-violence. Feel free to make the cube so that students can see the 3-D model.

Teaching Tolerance recommends the following *Free at Last* topics for cubing:

- “Jim Crow” laws (pages 6)
- Segregation (pages 17-20)
- Freedom Rides (pages 17-19)
- Freedom Summer (pages 27-29)

### Making the Cube

1. Cut along SOLID lines.
2. Crease along DOTTED lines.

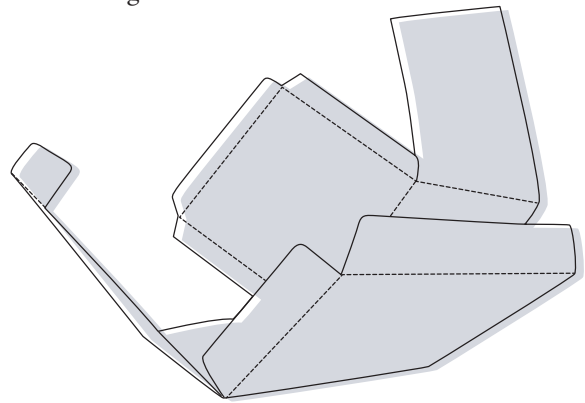

3. Tape or glue flaps at corners of cube.

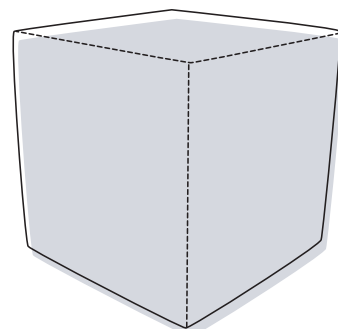
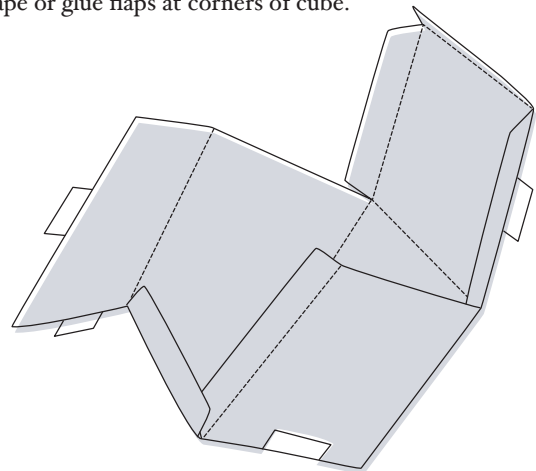

**CUBE: NON-VIOLENCE**

**DESCRIBE IT**

*Non-violence is calm,  
peaceful. It is  
non-injury to all  
things.  
It is boycotting,  
striking, marching,  
non-cooperation and  
civil disobedience.*

**ASSOCIATE IT**

*It reminds me of  
when somebody on  
another sports team  
has bad manners, but  
we still act kind and  
appropriate  
to them.*

**COMPARE IT**

*It is really the exact  
opposite of what you  
see most people do  
when they get mad.  
Most want to get  
even. Non-violence  
says let their act of  
violence indict them.*

**ARGUE FOR OR  
AGAINST IT**

*I am for it completely.  
You can't fight  
violence with more  
violence. That gets  
you nowhere.*

**ANALYZE IT**

*Gandhi first used it  
in India. King used it  
in America for civil  
rights. It is more than  
"not to hurt." It is a  
positive love for all  
things and all people.  
It is a way of life.*

**APPLY IT**

*Use it when someone  
calls you a name.  
Use it when someone  
gossips about you; you  
don't have to gossip  
back to get even.*

# CUBE

Topic: \_\_\_\_\_

## DESCRIBE IT

← Examine the subject closely and describe what you see.

↙ What is it similar to? Different from?

What does the subject make you think of? →

## ASSOCIATE IT

## COMPARE IT

↙ Use any kind of reasoning to take a stand for or against the subject.

## ARGUE FOR OR AGAINST IT

## ANALYZE IT

← Break the subject into parts; tell how it is made.

### To complete your cube...

1. Cut along SOLID lines.
2. Crease along DOTTED lines.

Describe the subject's uses. →

## APPLY IT

3. Tape or glue flaps at corners of cube.

